



FlowTek®

A Subsidiary of BRAY INTERNATIONAL, Inc.

3 Piece Tube Bore Ball Valves, 1/2" - 4" High Purity Applications



Micro Pure Series

Model S7500
Model S7700

Flow-Tek's Micro Pure Series ball valves have been specifically designed to meet the requirements of high purity applications in accordance with ASME BPEa specification. All valve bodies are investment cast CF3M (316L) Stainless Steel with an internal surface finish of 15 Ra with 20 Ra maximum per SFV-1. Other grades of surface finishes, including electropolishing are available. Cavity fillers and purge ports are also available upon request.

Tube Bore The ball and end connections of all Micro Pure Series valves have the same I.D. dimension as the mating tube system. These valves offer smooth flow characteristics with minimal pressure drop and full-drain capability.

Processing To prevent component contamination, Micro Pure Series valves are solution cleaned, assembled and bagged to allow for use in high purity systems.

Pressure Rating:

Max: 1000 psi WOG
(dependent on end connection selected)

End Connections:

- Quick Clamp
- Extended Tube End
- SAE Male

End connections are interchangeable within the Micro Pure Series.





Features



Ball Flow-Tek balls are precision machined and mirror finished for bubble-tight shut off and reduced operating torque.

Seat Flow-Tek's unique seat design ensures bi-directional sealing while providing the lowest possible torque.

Seat Selection Optional seat materials, such as TFM 1600, are available to meet most applications, with the standard seat being Virgin PTFE. Optional seat designs, such as Cavity Fillers, are also available upon request.

Body 1/2"–4" valve bodies are investment cast stainless steel and all bodies are solution annealed for the highest quality and added strength. All body castings are marked with a foundry heat number for full traceability. The three piece body design offers many advantages, including installation flexibility, elimination of the need of flanges, and ease of in line or out of line servicing.

Body Hinges Two heavy duty body bolt hinges, throughout the entire size range, provide positive alignment of body to end connection during in-line servicing.

End Connections The Micro Pure Series features two standard interchangeable end connections – Quick Clamps for ease of installation and Extended Tube Ends for weld in place service.

Secure Mount A unique standard feature is an integrally cast top flange that ensures positive actuator mounting. Flow-Tek's Secure Mount eliminates unwanted actuator movement during high cycle or continuous duty applications. Actuation equipment can be easily and safely removed while the valve is under full line pressure. The Secure Mount through 2" valve sizes is in compliance with ISO 5211 bolting pattern standards.

Handles 1/2"–2" manually operated valves feature as standard a Safety Trigger to prevent accidental movement of the valve handle. The trigger locks the handle in the open or closed position. The handle lock can be overridden, if needed, with a small bolt through the handle in the release position. An oval handle is also available as an option.

Padlock A padlock can be added to secure the handle in position, preventing unwanted access. Available as standard on all valve sizes.

Smart Stem Assemblies

Flow-Tek manufactures heavy duty, high quality stems. All Flow-Tek stems are internal entry and blowout proof for maximum safety. Micro Pure Series valves feature strong, large diameter stems with live-loaded, self-adjusting primary and secondary sealing. Utilizing belleville washers, the stem seal automatically adjusts to compensate for changes in temperature and normal wear. The assembly is secured by a saddle-type lock washer, preventing unthreading of stem nuts in high cycle automation applications.

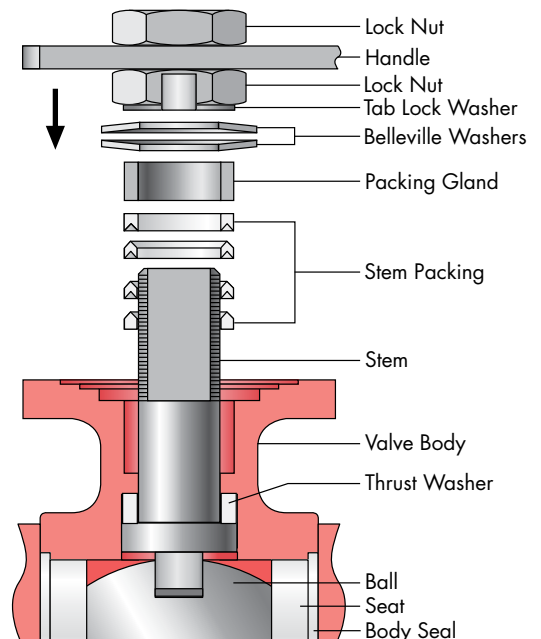

Stem Seals The Thrust Washer provides the primary seal while the live loaded Stem Packing creates a multiple secondary seal between the stem and body. The stem packing is also composed of PTFE providing high purity protection and high cycle life. This dual stem seal arrangement is a Flow-Tek exclusive.

Double Lock Nut Design Standard on the Micro Pure Series, the double lock nuts with tab lock washer allow handles to be easily and safely removed while the valve is under full line pressure.

Specifications

Valve Sizes 1/2" through 4"

Valve designs are in accordance with ASME BPEa High Purity Valves.

Valve bodies and end connections are high quality investment cast and solution annealed. Body shell wall thickness complies with ASME B16.34.

BPEa compliant with < 3% ferrite and .005 to .017 sulfur content in the extended tube ends for orbital welding.

Valve stems are blow-out proof for maximum safety and comply with ASME B16.34.

All standard materials of construction comply with FDA requirements and all soft goods meet USP Class VI standards.

Pressure Ratings

Valve Body 1000 psi WOG
Steam Rating 150 psi WSP
Vacuum 29 inches Hg gauge

Pressure / Temperature

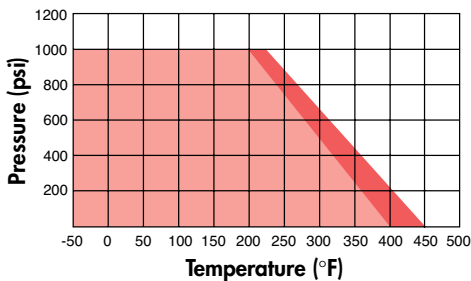

Light Red: 1/2" - 4" Valves: PTFE
 Dark Red: 1/2" - 4" Valves: TFM 1600

Internal Surface Finishes

BPE Designation	Ra Average	Ra Max
SFV1 *	Mechanical Polished 15	20
SFV4	Mechanical and Electropolished 10	15

*Flow-Tek standard

Flow-Tek offers the seat/body seal, thrust washers, and soft material stem packing as recommended spare parts. These parts are available as a packaged repair kit.

Components & Materials

For Valve Sizes 1/2" through 2"

For 2 1/2" - 4" consult factory.

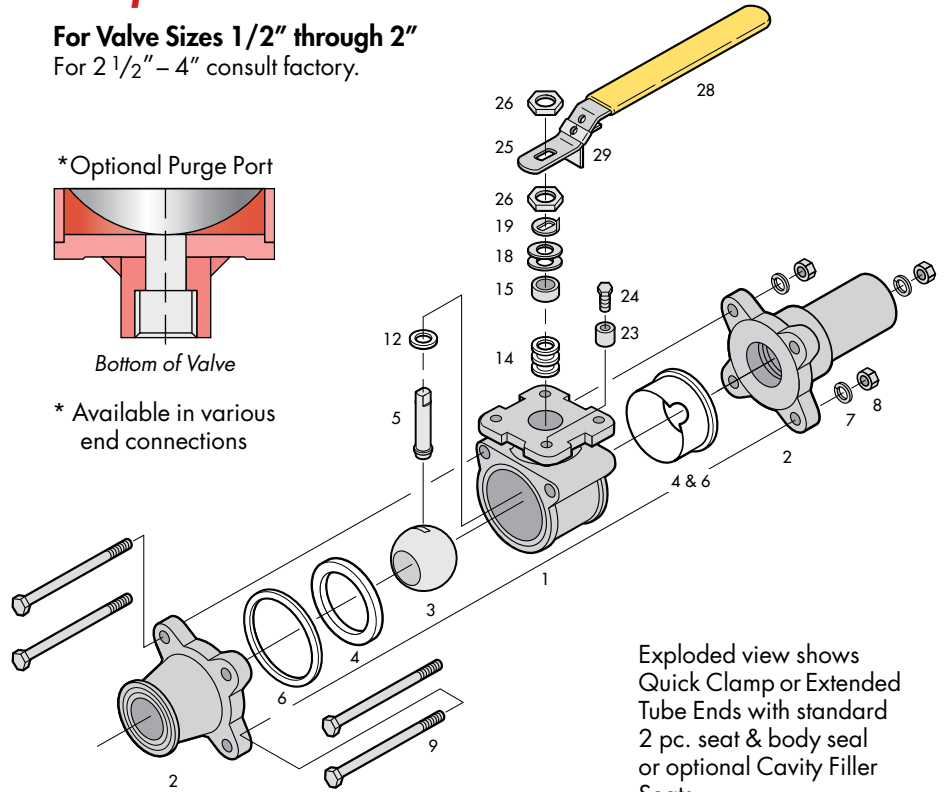

Exploded view shows Quick Clamp or Extended Tube Ends with standard 2 pc. seat & body seal or optional Cavity Filler Seats.

Item	Name	Material	Qty.
1	Body	ASTM A351 Gr CF3M†	1
2	End Cap	ASTM A351 Gr CF3M†	2
3	Ball	ASTM A351 Gr CF3M†	1
4 & 6	Seat/Cavity Filler & Body Seal*	PTFE	2
5	Stem	ASTM A479 Type316	1
7	Spring Washer	SS304	4**
8	Body Nut	SS304	4**
9	Body Bolt	SS304	4**
12	Thrust Washer	PTFE	1
14	Stem Packing	PTFE	3
15	Packing Gland	SS304	1
18	Belleville Washer	SS301	2
19	Tab Lock Washer	SS304	1
23	Travel Stop Set Sleeve	SS304	1
24	Travel Stop Bolt	SS304	1
25	Handle	SS304	1
26	Lock Nut	SS304	2
28	Handle Sleeve	Vinyl	1
29	Locking Device	SS304	1

†Sizes 2 1/2", 3 and 4" are ASTM A351 Gr CF8M.

*Standard valve has a seat and body seal. Cavity Filler and Body Seal are optional.

**Quantity is 6 for 3" and 4" valves.

Dimensions

MODEL S7500 & MODEL S7700

Size ins mm	A1	A2	øB Port	øB1	C	C1	D	E	Cv	WEIGHT lbs./kg.	BOLT TORQUE lbs-ins/Nm	BREAK TORQUE lbs-ins/Nm	
												w/o Cavity Filler	w/ Cavity Filler
1/2 15	3.602 91.5	6.00 152.4	0.370 9.4	0.370 9.4	2.60 66	1.535 39	6.496 165	1.50 38.1	9.5	2 0.9	150 17	42 4.8	55 6.2
3/4 20	4.114 104.5	6.00 152.4	0.620 15.8	0.620 15.8	2.60 66	1.535 39	6.496 165	1.50 38.1	30	3 1.4	150 17	70 7.9	90 10.2
1 25	4.480 113.8	6.50 165.1	0.870 22.1	0.870 22.1	2.91 73.9	1.658 42	6.496 165	1.50 38.1	65	4 1.8	150 17	115 13	150 17
1 1/2 40	5.055 128.4	7.50 190.5	1.370 34.3	1.370 34.3	3.62 91.9	2.254 57.3	7.874 200	1.50 38.1	205	7 3.2	280 32	285 33	370 42
2 50	5.748 146	8.50 215.9	1.870 47.5	1.870 47.5	4.53 115.1	2.953 75	9.842 250	1.50 38.1	420	10 4.5	285 32.2	465 53	605 69
2 1/2 65	6.850 174	10.0 254	2.370 60.2	2.370 60.2	5.04 128	3.386 86	9.646 245	1.50 38.1	430	20 9.1	330 37	650 74	845 96
3 80	7.402 188	11.5 292.1	2.870 72.9	2.870 72.9	6.42 163.1	3.720 94.5	15.354 390	1.75 44.4	675	32 14.5	600 68	950 108	1235 140
4 100	8.758 222.5	12.5 317.5	3.834 97.4	3.834 97.4	7.09 180.1	4.350 110.5	15.354 390	2.00 50.8	1110	55 24.9	650 73	3000 339	3900 441

Note: Torque at maximum rated pressure, clean water, PTFE seats. Refer to Technical Bulletin 1005 for complete torque information. Bolt torques are provided for proper reassembly of valve bodies after disassembly for installation or cleaning.

SECURE MOUNT

Size ins mm	H	J	K	L	M	øP	U UNC
1/2 15	1.169 29.7	1.169 29.7	0.35 8.9	0.61 15.5	0.250 6.35	0.375 9.5	#10-24
3/4 20	1.169 29.7	1.169 29.7	0.35 8.9	0.61 15.5	0.250 6.35	0.375 9.5	#10-24
1 25	1.169 29.7	1.169 29.7	0.40 10.2	0.61 15.5	0.250 6.35	0.375 9.5	#10-24
1 1/2 40	1.392 35.4	1.392 35.4	0.51 13	0.80 20.3	0.315 8	0.438 11.1	1/4"-20
2 50	1.949 49.5	1.949 49.5	0.62 15.8	0.94 23.9	0.374 9.5	0.625 15.9	5/16"-18
2 1/2 65	2.840 72.1	2.840 72.1	0.82 20.8	1.22 31	0.472 12	0.750 19.1	5/16"-18
3 80	3.543 90	1.874 47.6	1.752 44.5	3.00 76.2	0.669 17	1.102 28	1/2"-13
4 100	3.543 90	1.874 47.6	1.752 44.5	3.00 76.2	0.669 17	1.102 28	1/2"-13

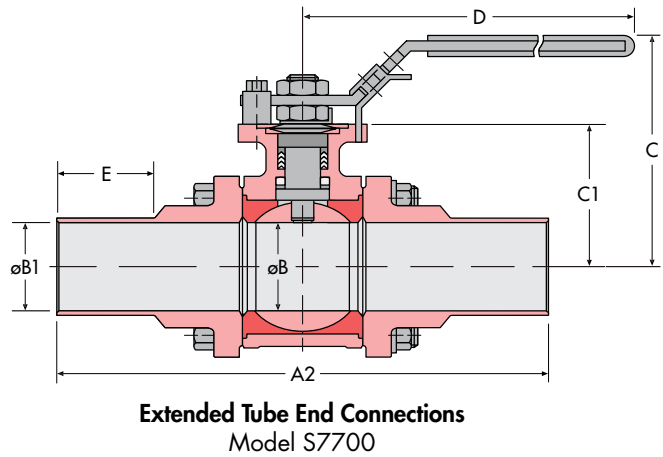
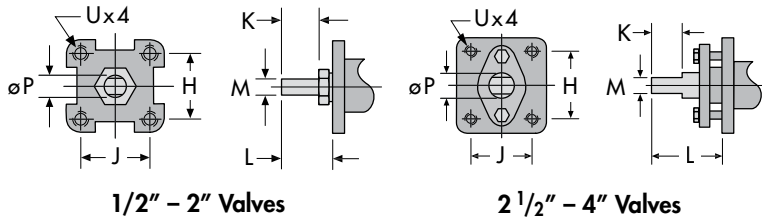

SAE Male End Connections also Available

